

ORCA-R²



Technical note

1. Introduction	P2
2. Technologies of cooled CCD cameras	P2
2.1 Hermetic vacuum-sealed chamber	
2.2 Advantages of an Interline Transfer CCD (ER-150 CCD)	
2.3 Readout noise	
2.4 Dark current	
2.5 Frame rate	
2.6 Binning	
2.7 Sub-array	
3. New features of ORCA-R2	P4
4. Features of ORCA-R2	P4-8
4.1 Cooling structure	P4
4.1.1 Small hermetic vacuum-sealed chamber	
4.1.2 Dual cooling	
4.2 Thermal charge	
4.3 Low readout noise	P5
4.4 Dual light mode	
4.5 Readout method	
4.5.1 Dual scan	
4.5.2 Binning / sub-array	
4.5.3 Dual A/D converter	
4.5.4 Analog gain enhancement	
4.5.5 High dynamic range	P6
4.6 New IEEE1394b high speed interface	
4.7 External trigger mode	
4.7.1 Edge trigger	
4.7.2 Level trigger	
4.7.3 Synchronous readout trigger	
4.7.4 Start trigger	
4.8 Synchronization output	P7
4.8.1 Exposure output	
4.8.2 Programmable timing out	
4.8.3 Trigger ready out	
4.9 Camera Structure	
4.10 Operational environment - ambient temperature and humidity	
4.11 Power supply	
4.12 Specifications	P8
4.13 Dimensional Outlines	



1. Introduction

The Hamamatsu ORCA series of cooled CCD cameras have earned a world wide reputation in many fields of scientific quantitative imaging. The newest addition to the series, the ORCA-R2, brings new features and improved specifications to the series and is the successor to the ORCA-ER and ORCA-AG cameras.

This technical note is intended for users of the ORCA-R2 and contains explanations of the new features and important information about the proper use of the camera for quantitative imaging.

2. Technologies of cooled CCD cameras

This chapter reviews some of fundamental technologies required for scientific cooled CCD cameras.

2.1 Hermetic vacuum-sealed chamber

Based on the many years of experience producing vacuum tubes for photomultiplier (PMT) and Image Intensifier (II) devices, Hamamatsu Photonics K.K. created a proprietary vacuum chamber, (called a Hermetic vacuum-sealed chamber) in order to improve cooling performance for the CCD camera. The hermetic vacuum-sealed chamber contains both the CCD chip and peltier element (Thermo-electric cooling device) within the welded metal chamber. This structure provides a permanent high vacuum level with multiple benefits.

- Maintenance-free

The hermetic vacuum-sealed chamber is maintenance-free. Periodic re-evacuation is not needed. The hermetic vacuum-sealed chamber will stably maintain high vacuum compared to ordinary gasket or O-ring structures.

- Efficient cooling

The hermetic vacuum-sealed head cools the CCD efficiently by using with the high vacuum levels inside the chamber to minimize heat convection. The cooling is much more efficient compared to Nitrogen purged or insufficiently evacuated structures.

- Condensation free (within chamber)

No condensation is possible within the chamber since there is no moisture in such a high vacuum environment.

- Condensation free (outside chamber)

No condensation will occur outside the chamber either. The same high degree of vacuum that insulates the CCD within the chamber also prevents thermal convection with the exterior of the chamber. Since there is no temperature drop at the window or surface of the chamber, no condensation can occur. This is a major advantage when compared to Nitrogen purged or insufficiently evacuated structures.

2.2 Advantages of an Interline Transfer CCD (ER-150 CCD)

There are three well known types of CCDs in scientific imaging. One is the interline transfer CCD (IL-CCD) the second is full frame transfer (FFT-CCD) and the third is the frame transfer CCD (FT-CCD). The IL-CCD is used in the ORCA-R2.

The structure of an IL-CCD is shown in Figure 1(a). The interline CCD has vertically paired columns consisting of imaging Photodiodes (PD) and a readout register, sometimes called the Vertical charge transfer register (V-CCD). Electrons generated by incoming photons in each PD are shifted simultaneously to the adjacent V-CCD register. The V-CCD register is covered by a mask of aluminum or other opaque mate-

rial to prevent photons from creating additional charges in this area, so only the charges generated in the PDs are included in the readout. Readout is accomplished by transferring each horizontal row of information in the V-CCD, line by line, up the CCD to the Horizontal serial register (H-CCD). There, charges are transferred horizontally and converted into charge voltage by an amplifier (AMPFDA).

The design of an IL-CCD has the advantage that the signal accumulation (exposure) and readout can be done simultaneously because PD can accumulate charges for the next frame right after the previously generated electric charges in the PD are shifted to the V-CCD. There is no possibility of image smearing in this device.

In earlier versions of the IL-CCD design there was the disadvantage that the open ratio of the light sensitive area (fill factor) was reduced because of the presence of the masked V-CCD area. Recently this disadvantage has been dramatically improved by the addition of on-chip lenses (as shown in Figure 2) and improvements have been made to the sensor structures that allow detection of photons deeper in the PD than previous models. Overall Quantum efficiency has increased to over 70 %. New IL-CCDs like the Hamamatsu ER-150 CCD (Figure 3) used in the ORCA series of cameras, offer characteristics ideally suited to many scientific applications

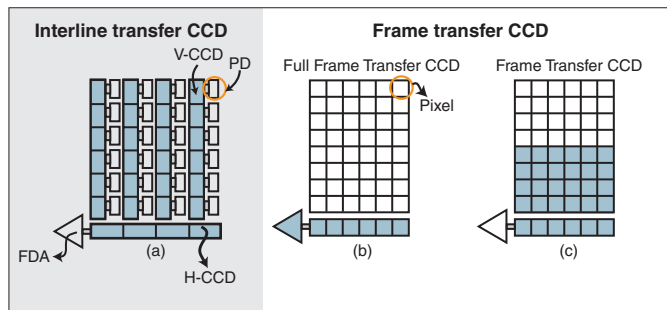

Fig. 1 Three types of CCD structure

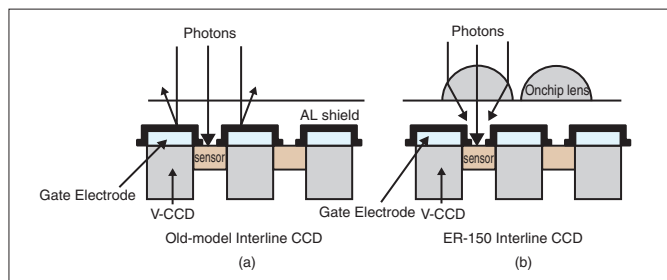

Fig. 2 The interline transfer CCD structure with onchip lens

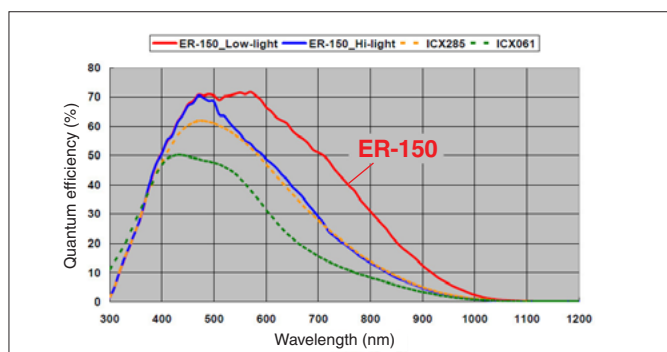

Fig. 3 QE of the ER-150 interline transfer CCD (See line in red.)

2.3 Readout noise

Silicon (SI) based CCD technology has produced remarkable innovations and a large number of detectors using different designs. Quantum efficiency (QE) of CCD detectors is close to the theoretical maximum. For example, QE of the Interline CCD is over 70% and the Back-thinned CCD is over 90%. In this situation, readout noise and CCD dark current are the remaining factors that determine the detection limit of a CCD. These values have a great impact on the performance of the camera.

The largest factor influencing the detection limit of a CCD is the readout noise caused by the on-chip floating diffusion amplifier (FDA) that converts accumulated charges into voltage. Accumulated charges transferred into the horizontal serial register are serially transferred into the FDA pixel by pixel. Readout noise is primarily caused by the resetting of the amplifier after the accumulated charge in each pixel is converted to a voltage and the amplifier is reset for the next incoming pixel. This reset noise can be dramatically reduced by an external correlated dual sampling (CDS) circuit. Additionally, readout noise depends on pixel clocking frequency and is generally lower with slower CCD clocking speeds. However, slower pixel clock speeds may limit the camera's use for dynamic real-time imaging. In summary, camera readout noise performance depends greatly on the external circuit design of the camera manufacturer and the readout speed.

2.4 Dark current

There are two elements of dark current. One is the clock-induced charge and the other is thermal charge. Clock-induced charge is the charge generated when electric potential is changed in order to transfer charge. Generally, it is negligible since it is less than 1 electron compared to the readout noise which is several electrons or more.

Since a CCD is made from silicon, the dark current is caused by thermal migration of electrons in the silicon. This migration is called thermal charge or dark current and can be an important noise factor for a CCD sensor. The dark current of a CCD depends on the temperature and it decreases by half when the temperature drops by approximately 7 to 8 degrees C. It is apparent that cooling a CCD is a very good way to reduce the dark current. Fig. 4 shows the CCD dark current vs. Temperature.

Dark current also depends on the type of CCD. In most applications, an IL-CCD normally has lower dark current than other designs and will achieve good performance with -30 degrees C cooling.

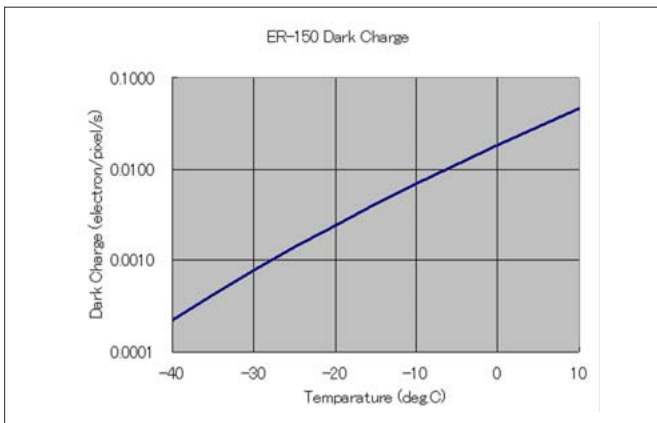

Fig. 4 CCD dark current vs temperature

2.5 Frame rate (readout speed)

The frame rate is the number of consecutive images output per second and is usually expressed in frames per second (fps) or Hertz (Hz). This frame rate determines how clearly a moving image can be captured or the minimum interval between consecutive images. This is often a crucial factor when selecting a camera.

Frame rate depends on the number of pixels that are to be readout and the speed of the pixel clock used to read the pixels through the FDA. Changing either of these numbers will affect the frame rate and may influence the readout noise. Binning and sub-array are two methods of changing the number of pixels to be readout and each has some side effects that should be considered.

2.6 Binning

By summing signals of adjacent pixels in a CCD, the binning readout method delivers high sensitivity, improved signal to noise, and increased frame rate as a tradeoff for resolution. Fig. 5 shows the basic principle of the binning operation. In 2x2 binning, the electrical charge of 4 pixels is summed in the CCD to increase the signal component 4-fold, but the readout noise is still only equal to 1 readout period so the S/N ratio is improved. Binning selections of 2x2, 4x4, and 8x8 are standard.

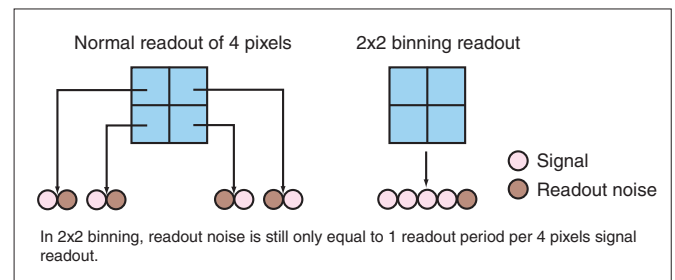

Fig. 5 Principle of binning

2.7 Sub-array

In this method, a selected area is created within the CCD and only the signal from pixels within that selected area are readout from the CCD. The CCD charge on areas other than the selected one are dumped at high speed. Fig. 6 shows the basic principle of sub-array readout. Using this method drastically cuts the time needed for reading each frame and allows an increase in the frame rate without loss of resolution. No increase in the S/N ratio is achieved with this method. The frame rate can be raised even higher by combining sub-array with binning mode.

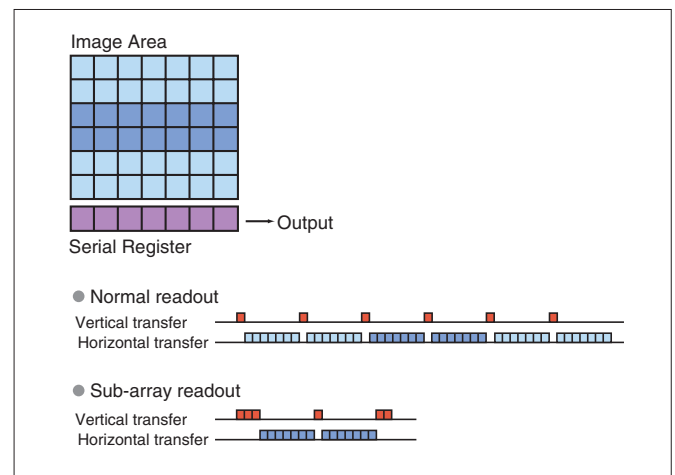

Fig. 6 Principle of sub-array

3. New features of ORCA-R2

This chapter summarizes the new features of the ORCA-R2 compared to ORCA-ER and ORCA-AG.

● Dual scan

A fast scan mode is implemented in ORCA-R2 that doubles the frame rate compared to ORCA-ER and ORCA-AG. (See 4.5.1.)

● High dynamic range mode

High dynamic range mode is implemented in ORCA-R2 providing increased full well capacity when the binning mode and normal scan rate are used together. (See 4.5.5.)

● Dual A/D converter

Digitizer bit depth can be selected from either 12 bit or 16 bit by software command. (See 4.5.3.)

● Dual cooling

Water cooling or air cooling method is selectable. (See 4.1.2.)

● IEEE1394b interface

ORCA-R2 has IEEE1394b interface for faster data transfer. (See 4.6.)

● New external trigger mode

External trigger mode is implemented in ORCA-R2 in order to synchronize with other external equipment. (See 4.7.)

● New synchronous output

Synchronous signal is implemented in ORCA-R2 in order to synchronize with another ORCA-R2. (See 4.8.)

4. Features of ORCA-R2

This chapter reviews features of the ORCA-R2.

4.1 Cooling structure

ORCA-R2 has a hermetic vacuum-sealed chamber including dual cooling methods.

4.1.1 Small hermetic vacuum-sealed chamber

ORCA-R2 has a newly designed and relatively smaller vacuum chamber than previous models and a specially developed high performance peltier element. This combination makes it possible to have a small, light camera head that can maintain cooling levels and prevent condensation over a wider range of ambient conditions than before. The design incorporates a single window with no cover glass on the CCD for better light transmission and reduced reflections. More details about this can be found in chapter "2.1. Hermetic vacuum-sealed chamber."

4.1.2 Dual cooling

ORCA-R2 has dual cooling methods, providing both air-cooling and water cooling. The new peltier element in ORCA-R2 has an improved heat release structure so that air cooling alone is sufficient to maintain the camera cooling specifications with the fan on in most applications. The cooling fan can be switched off, even in air cooling mode. However, in that case, sufficient cooling performance cannot be guaranteed. If the fan needs to be turned off for more than a few moments, water cooling mode is recommended to provide the best performance.

When water cooling is chosen, a water circulator is required. Read the instruction manual carefully and follow the instructions regarding water temperature, ambient temperature and humidity to prevent condensation in the camera head. While the vacuum chamber protects the detector from condensation, other parts of the camera may be subject to condensation in extreme environments.

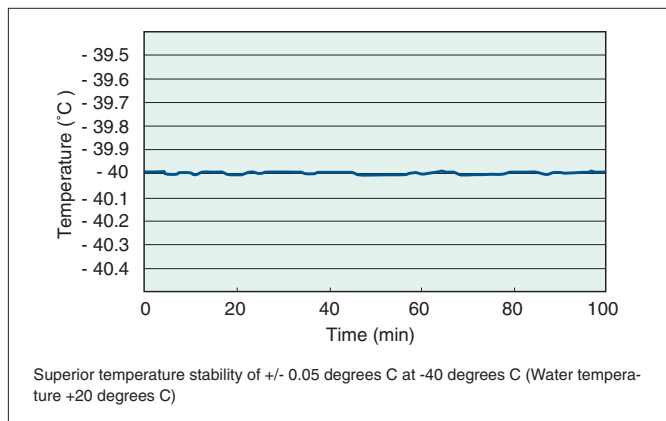

Fig. 7 Temperature stability

4.2 Thermal charge

As mentioned in chapter "2.4. Dark current", thermal charge largely depends on CCD type. ORCA-R2 incorporates the ER-150 chip which is an interline CCD. The Thermal charge of the ER-150 is 0.0005 electrons / pixel / s (typ.) at a temperature of -40 degrees C. At this temperature and with an exposure of 4200 sec (the maximum exposure time of ORCA-R2), the thermal charge is less than 2.1 electron / pixel. This is less than one count in the digitizer and the thermal charge is almost undetectable for any exposure at this temperature.

4.3 Low readout noise

Based on extensive experience accumulated over many years of CCD camera production, the ORCA-R2 utilizes a dual optimized circuit design. Since ORCA-R2 features an especially fast 28 MHz pixel clock in the fast readout mode, implementing optimized and separate circuits provides minimum readout noise for each speed. The benefits of this dual circuit design are illustrated in the value of only 6 electrons readout noise in normal (14MHz) readout mode and only 10 electrons readout noise in fast (28MHz) readout mode. More details about this are found in chapter "2.3. Readout noise".

4.4 Dual light mode

The ER-150 interline CCD is the heart of the ORCA-R2 and is used in many other ORCA cameras as well. This CCD is well suited for both normal intensity and low light intensity applications thanks to the flexible high light and low light modes of operation. The high light mode is used for most applications and the low light mode is used when increased quantum efficiency in the spectrum between visible and near infrared is required (See Fig 3.). The high resolution imaging array on this CCD consists of 6.45 x 6.45um pixels in a1344 x 1024 2/3 inch format.

The maximum quantum efficiency is over 70 %, providing high sensitivity in the visible to near infrared region. Furthermore, it has sensitivity beginning at 300nm.

4.5 Readout method

ORCA-R2 has various combinations of readout modes. The following descriptions provide information about these modes and the manner in which they may be combined.

4.5.1 Dual scan

ORCA-R2 has two scan modes. The first is the normal scan mode with a readout speed of 14MHz. This is similar to the scan speed of ORCA-ER and ORCA-AG and provides about 8.5 frames per second at full resolution. Second is the fast scan mode with a readout speed of 28MHz available only in the ORCA-R2. In the fast scan mode, the readout speed is doubled, providing 16.2 frames per second at full resolution. The separately optimized circuits used in the ORCA-R2 provide this dual speed feature with minimal readout noise in each mode.

4.5.2 Binning / sub-array

ORCA-R2 has both binning and sub-array features that can be used in either readout mode.

Binning formats of 2x2, 4x4, and 8x8 binning are available standard. Using binning improves sensitivity and frame rate in a trade-off with spatial resolution. Sub-array enables faster frame rates in a trade-off with field of view. The following chart shows the fastest frame rates for combinations of binning and sub-array in either of the readout modes.

The fastest frame rate combined with binning and sub-array feature is fast as 115.1 Hz in fast scan mode.

Fastest readout noise

[Normal scan] (Unit : frame/s)

Binning	Sub-array (Effective pixel of vertical direction)							
	1024	512	256	128	64	32	16	8
1x1	8.5	15.6	26.7	41.4	57.2	70.6	80.0	85.7
2x2	15.6	26.7	41.4	57.2	70.6	80.0	85.7	88.8
4x4	26.7	41.4	57.2	70.6	80.0	85.7	88.8	90.5
8x8	40.6	56.3	69.8	79.2	85.0	88.2	89.9	90.8

[Fast scan] (Unit : frame/s)

Binning	Sub-array (Effective pixel of vertical direction)							
	1024	512	256	128	64	32	16	8
1x1	16.2	28.4	45.7	65.6	83.9	97.5	106.2	111.1
2x2	28.4	45.7	65.6	83.9	97.5	106.2	111.1	113.7
4x4	45.7	65.6	83.9	97.5	106.2	111.1	113.7	115.0
8x8	64.3	82.7	96.5	105.3	110.3	113.0	114.4	115.1

Fig. 8 Frame rate with binning and sub-array

4.5.3 Dual A/D converter

The dual readout modes also incorporate dual (12 or 16 bit) digitizers. In applications when a small quantization error* is required the 16 bit digitization is the recommended choice.

* Quantization error is defined as the error caused by rounding up when an analog signal is converted to a digital signal. The error becomes smaller as the bit number increases.

4.5.4 Analog gain enhancement

ORCA-R2 has analog gain and analog offset which may be applied to either readout mode. Analog gain is an analog signal multiplication before the analog signal is converted to a digital signal. Thus, it is effective to reduce quantization errors in the AD converter. Be aware that when the analog gain is raised, the conversion factor* of the camera is changed as well.

Analog offset is used to raise contrast of the image when combined with analog gain. If the input range of the AD converter is exceeded when analog gain is applied, use analog offset to reduce the input range. As a result of using both the gain and the offset features, the values between the gain and the offset settings are enhanced and a high contrast image can be obtained (See Fig 9.).

* Conversion factor is the ratio of CCD output electrons to output counts. It is expressed in units of "electrons / count". For example, a conversion factor of 4.4 electrons / count means 1 count of digital signal is equivalent to 4.4 electrons.

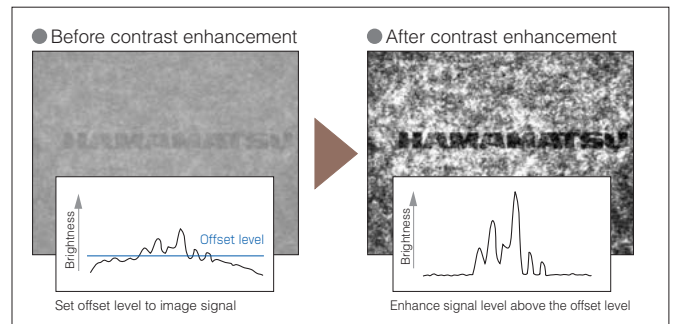

Fig. 9 Contrast enhancement comparison

4.5.5 High dynamic range

ORCA-R2 features a high dynamic range feature in the normal scan mode. High dynamic range takes advantage of the larger full well capacity of the horizontal transfer register pixels in comparison with the full well capacity of each imaging pixel. It is enabled in 2x2, 4x4 and 8x8 binning modes where the charges in the imaging pixels are summed in the horizontal transfer pixels. This feature is only available in normal scan mode since normal scan mode is able to transfer these large charges accurately.

In the high dynamic range mode, full well capacity is increased to 36 000 electrons.

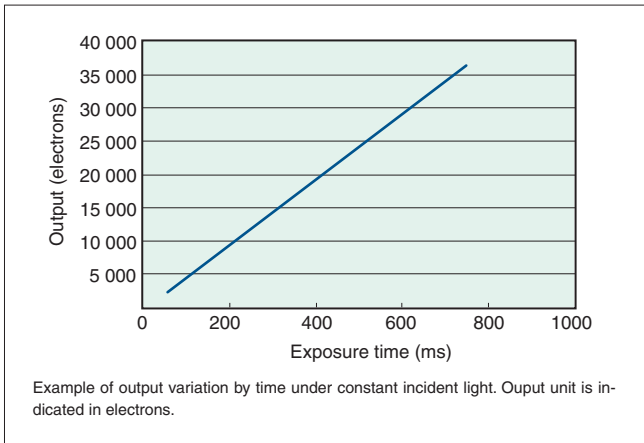

Fig. 10 Linearity in high dynamic range mode

4.6 New IEEE1394 b high speed interface

ORCA-R2 has IEEE1394b interface for fast data transfer. This interface can easily accommodate the 16.2Hz frame rate of the ORCA-R2 in fast scan mode and even the simultaneous images from two ORCA-R2 cameras when connected by the built-in daisy chain feature in the camera controller.

4.7 External trigger mode

In order to synchronize the ORCA-R2 with external equipment, the camera has four external trigger modes in which the external equipment is the master and the camera is the slave.

4.7.1 Edge trigger

Camera starts exposure upon input of a trigger pulse (positive or negative signal edge). The exposure time is set in the application software. When another trigger signal is input during the exposure time, the camera disregards the trigger signal until the exposure automatically ends. Readout begins at the end of exposure.

The following chart shows the example of the timing chart with positive edge signal.

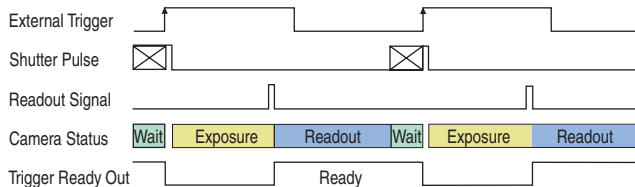

Fig. 11 Edge trigger

4.7.2 Level trigger

Camera starts exposure upon input of trigger pulse (positive or negative signal edge) and continues until the end of the trigger pulse. Readout begins at the end of exposure.

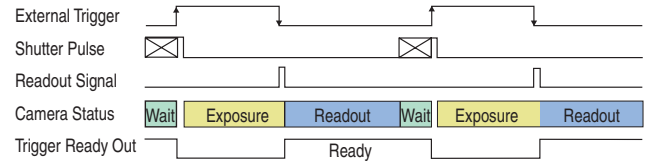

Fig. 12 Level trigger (positive edge)

4.7.3 Synchronous readout trigger

Camera starts exposure upon input of a trigger pulse (positive or negative signal edge) and continues until the correct number of trigger pulses (signal edges) have been received. The number of pulses is set in software. This mode is preferred because it allows the longest externally synchronized exposure time with the minimum dead time since the camera can exposure and readout at the same time. It also provides full synchronization of the camera with trigger pulses that have uncertain timing or jitter.

The trigger pulse number to start readout can be set (See Fig. 10). The upper figure shows the exposure when the number of trigger pulses is set as 1 and the lower figure shows the exposure when the number of pulses is set as 4.

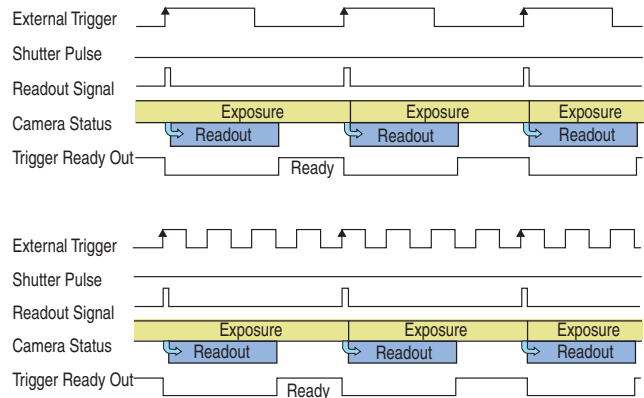

Fig. 13 Synchronous readout trigger (positive edge)

4.7.4 Start trigger

Camera starts exposure upon input of a trigger pulse (positive or negative signal edge) and is immediately switched to internal synchronization. This feature provides consecutive image acquisition from a single trigger pulse and the fastest frame rates due to the internal synchronization that allows the camera to expose and readout at the same time.

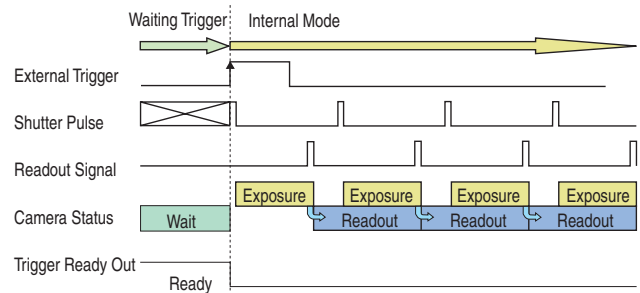

Fig. 14 Start trigger (positive edge)

4.8 Synchronous output

In order to synchronize other external equipment with the ORCA-R2, the camera provides various synchronization output signals making the ORCA-R2 the master and the external equipment becomes the slave.

4.8.1 Exposure output

Pulse output with the same timing as exposure timing.

4.8.2 Programmable timing output

A timing delay and the pulse length are programmed by command and synchronized to the start of exposure. This feature can be used as simple delay unit or pulse generator.

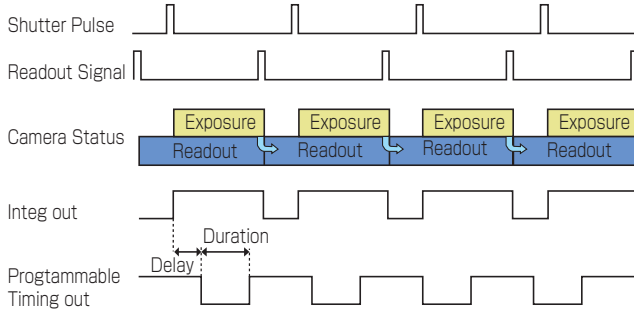

Fig. 15 Programmable timing out

4.8.3 Trigger ready out

During exposure a "standby" signal is output to indicate whether the next trigger pulse can be accepted or not.

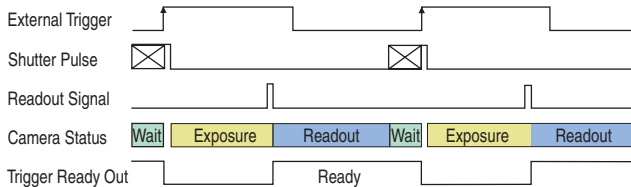

Fig. 16 Trigger ready out

4.9. Camera Structure

In comparison with previous ORCA-ER and ORCA-AG cameras the weight of the camera controller is reduced by almost 55 % from 6.2 kg to 2.8 kg. The physical dimensions of the controller are also reduced by 20% for easier handling and space savings. The dimensions of the camera head are identical except for the water connection spigots but the weight is reduced from 1.2 kg to 1.1 kg. The camera cable is thinner and the weight is reduced from 1.3 kg to 1.0 kg.

The sturdy C mount is retained from the previous models making it easy to firmly connect the camera to most optical equipment such as microscopes and confocal adapters.

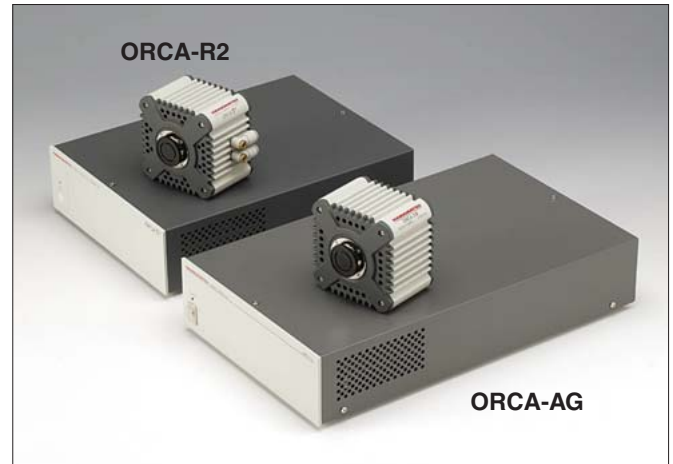

Fig. 13 Appearance of ORCA-R2 and ORCA-AG (back is ORCA-R2)

4.10 Operational environment - ambient temperature and humidity

Operational ambient conditions have significant importance for electrical devices. If the camera is operated out of the specified operational temperature range, the camera performance is not guaranteed and there is the possibility of damaging the camera. This is of special concern when a cooled CCD camera is operated in air-cooling mode where ambient temperature has a large influence on the cooling temperature of the camera. High ambient temperature may increase dark current and noise, especially for a high sensitivity camera which is more likely to be used within a blackout curtain or in a box. These types of environments reduce air flow and therefore the local ambient temperature increases. The controller environment is also of concern since it is often placed in a corner or in a stack of other equipment which may reduce airflow within the control box.

The operational ambient temperature of the ORCA-R2 is specified from 0 to 40 degrees C. Normal room temperature is estimated to be between 20 and 30 degrees C so a wide range of environments are considered normal for operation of the ORCA-R2.

Humidity is also important. When humidity is high, condensation might easily occur since the camera has cooling features. If some part of the camera is cooled significantly below the ambient temperature, humidity can become a significant factor. As mentioned in "chapter 2.1. Hermetic vacuum-sealed chamber" the CCD chip is protected by the vacuum chamber but other components are not.

The ORCA-R2 specifications allow for a wide range of applications and environments but care is still required for proper operation and safety.

4.11 Power supply

In the ORCA-ER and ORCA-AG the power supply voltage was set before shipment from the factory. ORCA-R2 is provided with a new power supply that automatically switches between 100 to 240 V, 50 / 60 Hz for easy and trouble free operation almost anywhere. Power consumption is reduced 30 % to 60 VA compared to earlier models as well. A new feature includes a color indicator in the switch on the face plate of the controller that indicates the status of the camera. "Orange", "Green" and "Red" indicate "Standby", "Operation" and "Trouble" respectively.

4.12. Specifications

Type number	ORCA-R2 (C10600-10B)	
Camera head type	Hermetic vacuum-sealed head	
Dual cooling	Air cooling / water cooling	
Imaging device	ER-150 progressive scan interline CCD	
Effective number of pixels	1344 (H) × 1024 (V)	
Cell size	6.45 μm (H) × 6.45 μm (V)	
Effective area	8.67 mm (H) × 6.60 mm (V)	
Dual scan mode	Normal scan / Fast scan	
Pixel clock rate	Normal scan	14.00 MHz/pixel
	Fast scan	28.00 MHz/pixel
Readout noise (r.m.s.) typ.	Normal scan	6 electrons
	Fast scan	10 electrons
Full well capacity typ.	High dynamic range mode ① OFF	18 000 electrons
	range mode ① ON	36 000 electrons
Dynamic range typ. ②	3 000 : 1 (at Normal scan / 1×1)	
Cooling method / temperature	Forced-air cooled	- 35 °C
	Water cooled	- 40 °C (Water temperature : +20 °C)
Dark current	0.0005 electrons/pixel/s (at - 40 °C)	
Dual A/D converter	12 bit or 16 bit	
Exposure time	10 μs to 4200 s	
Binning	2 × 2, 4 × 4, 8 × 8	
Sub-array	Yes	
Dual light mode	Low light mode / High light mode	
High dynamic range mode	Yes	
Analog gain feature	Yes (10times max.)	
Analog offset feature	Yes	
External trigger mode	Edge trigger, Level trigger, Synchronous readout trigger, Start trigger	
Trigger output	Integ output, Programmable timing output, Trigger ready out	
Lens mount	C-mount	
Interface	IEEE1394b-2002	
External control	IIDC 1394-Based Digital Camera Specification Ver.1.31	
Power requirements	AC 100 V to AC 240 V, 50 Hz / 60 Hz	
Power consumption	approx. 60 V·A	
Ambient storage temperature	- 10 °C to + 50 °C	
Ambient operating temperature	0 °C to + 40 °C	
Ambient storage/operating humidity	70 % max. (no condensation)	

① High dynamic range mode is only available in normal scan modewith binning.

② Calculated from the ratio of the full well capacity and the readout noise

● Fastest readout speed

【 Normal scan 】 (Unit : frame/s)

binning	Sub-array (Effective pixel of vertical direction)							
	1024	512	256	128	64	32	16	8
1 × 1	8.5	15.6	26.7	41.4	57.2	70.6	80.0	85.7
2 × 2	15.6	26.7	41.4	57.2	70.6	80.0	85.7	88.8
4 × 4	26.7	41.4	57.2	70.6	80.0	85.7	88.8	90.5
8 × 8	40.6	56.3	69.8	79.2	85.0	88.2	89.9	90.8

【 Fast scan 】 (Unit : frame/s)

binning	Sub-array (Effective pixel of vertical direction)							
	1024	512	256	128	64	32	16	8
1 × 1	16.2	28.4	45.7	65.6	83.9	97.5	106.2	111.1
2 × 2	28.4	45.7	65.6	83.9	97.5	106.2	111.1	113.7
4 × 4	45.7	65.6	83.9	97.5	106.2	111.1	113.7	115.0
8 × 8	64.3	82.7	96.5	105.3	110.3	113.0	114.4	115.1

4.13. Dimensional Outlines (Unit : mm)

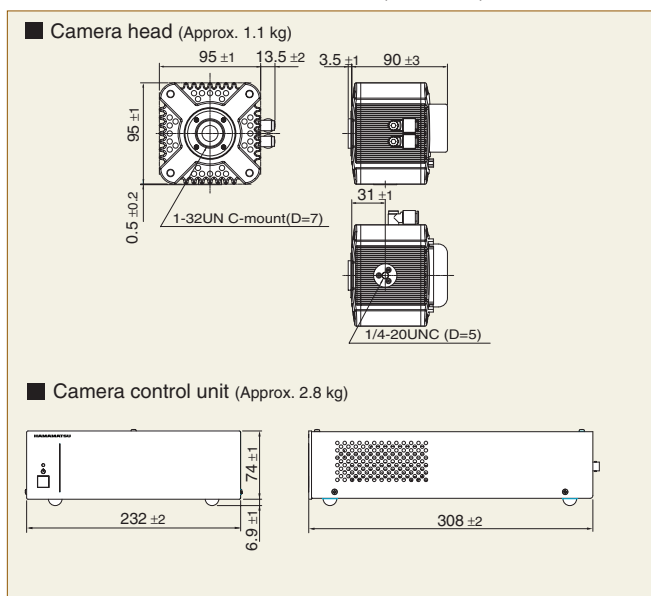

★ Windows is registered trademark of Microsoft Corporation in the U.S.A.

★ Product and software package names noted in this documentation are trademarks or registered trademarks of their respective manufacturers.

• Subject to local technical requirements and regulations, availability of products included in this promotional material may vary. Please consult with our sales office.

• Information furnished by HAMAMATSU is believed to be reliable. However, no responsibility is assumed for possible inaccuracies or omissions.

Specifications and external appearance are subject to change without notice.

© 2008 Hamamatsu Photonics K.K.

HAMAMATSU

HAMAMATSU PHOTONICS K.K., Systems Division

812 Joko-cho, Higashi-ku, Hamamatsu City, 431-3196, Japan, Telephone: (81)53-431-0124, Fax: (81)53-435-1574, E-mail: export@sys.hpk.co.jp

U.S.A. and Canada: Hamamatsu Corporation, Systems Division: 360 Foothill Road, Bridgewater, N.J. 08807-0910, U.S.A., Telephone: (1) 908-231-0960, Fax: (1) 908-231-0852, E-mail: usa@hamamatsu.com

Germany: Hamamatsu Photonics Deutschland GmbH: Arzbergerstr. 10, D-82211 Herrsching am Ammersee, Germany, Telephone: (49)8152-375-0, Fax: (49)8152-2658, E-mail: info@hamamatsu.de

France: Hamamatsu Photonics France S.A.R.L.: 19, Rue du Saule Trapu, Parc du Moulin de Massy, 91882 Massy Cedex, France, Telephone: (33)1 69 53 71 00, Fax: (33)1 69 53 71 10, E-mail: infos@hamamatsu.fr

United Kingdom: Hamamatsu Photonics UK Limited: 2 Howard Court, 10 Tewn Road, Welwyn Garden City, Hertfordshire, AL7 1BW, U.K., Telephone: (44) 1707-294888, Fax: (44) 1707-325777, E-mail: info@hamamatsu.co.uk

North Europe: Hamamatsu Photonics Norden AB: Smidesvägen 12, SE-171-41 Solna, Sweden, Telephone: (46)8-509-031-00, Fax: (46)8-509-031-01, E-mail: info@hamamatsu.se

Italy: Hamamatsu Photonics Italia S.R.L.: Strada della Moia, 1/E 20020 Arese (Milano), Italy, Telephone: (39)02-935 81 733, Fax: (39)02-935 81 741, E-mail: info@hamamatsu.it

Homepage Address <http://www.hamamatsu.com>

Cat. No. SCAS0055E02
SEP/2008 HPK
Created in Japan (500)